



DCA400SSI4F3PB Generator

UnitedGenerator.com
sales@unitedgenerator.com
707-332-0703 call or text to order

WhisperWatt™

Prime Rating — 320 kW (400 kVA)

Standby Rating — 336 kW (420 kVA)

3-Phase, 60 Hertz, 0.8 PF

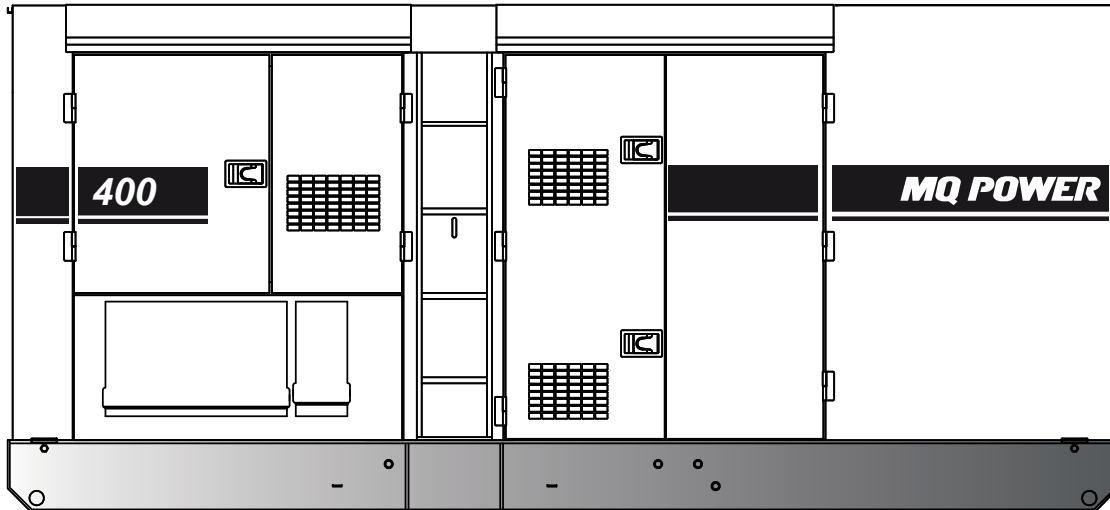

STANDARD FEATURES

- Heavy duty, 4-cycle, direct injection, turbocharged, charge air cooled diesel engine provides maximum reliability.
- EPA emissions certified — Tier 4 Final emissions compliant.
- Microprocessor engine control system maintains frequency to $\pm 0.25\%$.
- Full load acceptance of standby nameplate rating in a single step.
- Fuel/water separator removes condensation from fuel for extended engine life. Panel mounted alarm light included.
- Sound attenuated, weather resistant, steel housing provides operation at 69 dB(A) at 23 feet. Fully lockable enclosure allows safe unattended operation.
- E-coat with polyurethane enamel finish coat.
- Internal fuel tank with direct reading fuel gauges are standard.
- Brushless alternator reduces service and maintenance requirements and meets temperature rise standards for Class F insulation systems.
 - Open delta alternator design provides virtually unlimited excitation for maximum motor starting capability.
 - Automatic voltage regulator (AVR) provides precise regulation.
- Fully covered power panel. Three-phase terminals and single phase receptacles allow fast and convenient hookup for most applications including temporary power boxes, tools and lighting equipment. All are NEMA standard.
- Basler DGC2020HD microprocessor-based digital generator controller with integrated genset-to-genset (isolated bus) paralleling.
 - Onboard Synchronization and kW/kVAR load sharing.
 - Dual Ethernet ports for Inter-Genset communication.
 - High visibility backlit LCD display.
 - Operational temperature range of -40° to 70° C (-40° to 158° F).
 - Remote 2-wire start/stop control.
 - Metered power output parameters include:
 - Voltage
 - Amperage
 - Kilowatts
 - Kilovolt amps
 - Power Factor
 - Hertz
 - Modbus interface for gauge panel and expansion options.
 - Engine monitoring data over J1939. Modbus over RS485 for SCADA Interface.
- Digital engine gauges including oil pressure, water temperature, battery volts, engine speed, engine load, fuel level and DEF level.
- Analog generator instrumentation including AC ammeter, AC voltmeter, frequency meter, ammeter phase selector switch, voltmeter phase selector switch, and voltage regulator adjustment potentiometer.
- Automatic safety shutdown system monitors the water temperature, engine oil pressure, low coolant, low DEF, overspeed, and overcrank. Warning lights indicate abnormal conditions.
- Emergency stop switch — when manually activated, shuts down generator in the event of an emergency.



DCA400SSI4F3PB

Generator

UnitedGenerator.com
 sales@unitedgenerator.com
 707-332-0703 call or text to order

SPECIFICATIONS

| Generator Specifications | |
|---|---|
| Design | Revolving field, Self-ventilated Drip-proof, Single bearing |
| No. of Poles | 4-pole |
| Excitation | Brushless with AVR |
| Standby Output | 336 KW (420 kVA) |
| Prime Output | 320 KW (400 kVA) |
| Generator RPM | 1800 |
| Voltage — 3Ø | 208, 220, 240, 416, 440, 480V Reconnectable |
| Voltage — 1Ø | 120, 127, 139, 240, 254, 277V Adjustable |
| Armature Connection | Star with neutral |
| Voltage Regulation (No load to full load) | ±0.5% |
| Power Factor | 0.8 |
| Frequency | 60 Hz |
| Winding Pitch | 2/3 |
| Frequency Regulation: No Load to Full Load | Isochronous under varying loads from no load to 100% rated load |
| Frequency Regulation: Steady State | ±0.25% of mean value for constant loads from no load to full load. |
| Insulation | Class F |
| Sound Level dB(A) Full load at 23 feet | 69 |

| Engine Specifications | |
|---------------------------|--|
| Make / Model | Isuzu / BQ-6WG1X |
| Emissions | EPA Tier 4 Final Certified |
| Starting System | Electric |
| Design | 4-cycle, water cooled, direct injection, turbocharged, charge air cooled, EGR, DOC, and SCR. |
| Displacement | 15681 cc |
| No. cylinders | 6 |
| Bore x Stroke | 147 x 154 mm |
| Gross Engine Power Output | 512.3 hp (382 kWm) |
| BMEP | 236 psi (1624 kPa) |
| Piston Speed | 1819 ft/min (9.24 m/s) |
| Compression Ratio | 16.5 : 1 |
| Engine Speed | 1800 rpm |
| Overspeed Limit | 2070 rpm |
| Oil Capacity | 15.1 gallons (57 liters) |
| Battery | 12V 200Ah x 2 (24 V Systems) |

| Fuel System | | |
|--------------------------------|----------------------------|--------|
| Recommended Fuel | ASTM-D975-No. 1 & No. 2-D* | |
| Maximum Fuel Flow (per hour) | 98.8 gallons (374 liters) | |
| Maximum Inlet Restriction (Hg) | 8.86 in (225 mm) | |
| Fuel Tank Capacity | 55.5 gallons (210 liters) | |
| Fuel Consumption | gph | lph |
| At full load | 27.63 | 104.58 |
| At 3/4 load | 20.35 | 77.04 |
| At 1/2 load | 13.4 | 50.76 |
| At 1/4 load | 8.35 | 31.62 |
| DEF Tank Capacity | 14.8 gallons (56 liters) | |

* - Use ultra-low sulfur diesel fuel.

| Cooling System | |
|--|----------------------------|
| Fan Load | 17.8 hp (13.3 kW) |
| Coolant Capacity (with radiator) | 19.4 gallons (73.6 liters) |
| Coolant Flow Rate (per minute) | 111 gallons (420 liters) |
| Heat Rejection to Coolant (per minute) | 12,606 Btu (13.3 MJ) |
| Maximum Coolant Friction Head | 20.3 psi (140 kPa) |
| Maximum Coolant Static Head | 29.5 feet (9.0 meters) |
| Ambient Temperature Rating | 104°F (40°C) |

| Air | |
|---------------------------------|-----------------------------------|
| Combustion Air | 872 cfm (24.7 m³/min) |
| Maximum Air Cleaner Restriction | 25 in. H ₂ O (6.2 kPa) |
| Alternator Cooling Air | 2790 cfm (79.0 m³/min) |
| Radiator Cooling Air | 14129 cfm (400 m³/min) |

| Exhaust System | |
|-----------------------|-------------------------------------|
| Gas Flow (full load) | 1635 cfm (46.3 m³/min) |
| Gas Temperature | 968°F (520°C) |
| Maximum Back Pressure | 180.7 in. H ₂ O (45 kPa) |

| Amperage | |
|-----------------------------------|---------------------|
| Rated Voltage | Maximum Amps |
| 1Ø 120 Volt | 888.9 Amps (4 wire) |
| 1Ø 240 Volt | 444.4 Amps (4 wire) |
| 3Ø 208 Volt | 962.3 Amps |
| 3Ø 240 Volt | 962.3 Amps |
| 3Ø 480 Volt | 481.1 Amps |
| Main Line Circuit Breaker Rating | 1000 Amps |
| Over Current Relay Trip Set Point | 480 Amps |

WARRANTY*

Isuzu Engine**

12 months from date of purchase with unlimited hours or 36 months from date of purchase with 3,000 hours (whichever comes first).

Generator

24 months from date of purchase or 2,000 hours (whichever occurs first).

Trailer

12 months excluding normal wear items.

*Refer to the express written, one-year limited warranty sheet for additional information.
 **Refer to Isuzu Diesel Engine Limited Warranty for details.

NOTICE

Specifications sheet is subject to change and is not intended for use in installation design.



DCA400SSI4F3PB

Generator

UnitedGenerator.com

sales@unitedgenerator.com

707-332-0703 call or text to order

MQ POWER DECIBEL LEVELS

Our soundproof housing allows substantially lower operating noise levels than competitive designs. WhisperWatts are at home on construction sites, in residential neighborhoods, and at hospitals — just about anywhere.

- 90 — Subway / truck traffic
- 80 — Average city traffic
- 70 — Inside car at 60 mph
WhisperWatt at 23 feet
- 60 — Air conditioner at 20 feet
- 50 — Normal conversation



GENERATOR OUTPUT PANELS

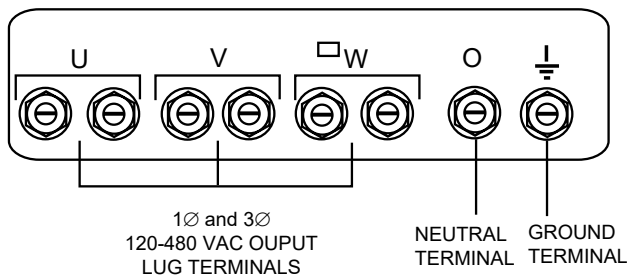
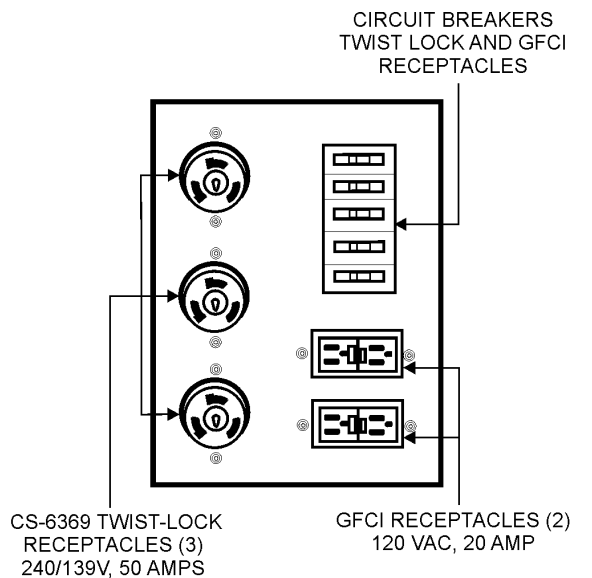

OPTIONAL GENERATOR FEATURES

- **PowerBalance™** — designed to assist generators when operating under low temperature and/or low load conditions to insure peak performance.
- **Battery Charger** — provides fully automatic and self-adjusting charging to the generator's battery system.
- **Jacket Water Heater** — for easy starting in cold weather climates.
- **Trailer Mounted Package** — highway legal trailer with electronic or surge brakes with double or triple axle configuration. Extra capacity fuel tanks are also available.

OPTIONAL CONTROL FEATURES

- **Audible Alarm** — alerts operator of abnormal conditions.

OPTIONAL FUEL CELL FEATURES

- **Trailer Fuel Tank** — a second fuel cell located in the trailer allows for extended run time.
- **Sub-base Fuel Cells (double wall)** — additional fuel cell for extended runtime operation. Contains a leak sensor, low fuel level switch, and a secondary containment tank. UL142 listed.
- 12 hours of minimum run time.
- 24 hours of minimum run time.

OPTIONAL OUTPUT CONNECTIONS

- **Cam-Lok Connectors** — provides quick disconnect alternative to bolt-on connectors.
- **Pin and Sleeve Connectors** — provides industry standard connectors for all voltage requirements.
- **Output Cable** — available in any custom length and size configuration.



DCA400SSI4F3PB

Generator

United Generator LLC

1964 Respite Pl, Santa Rosa, CA

sales@unitedgenerator.com 707-332-0703

SKID-MOUNT DIMENSIONS

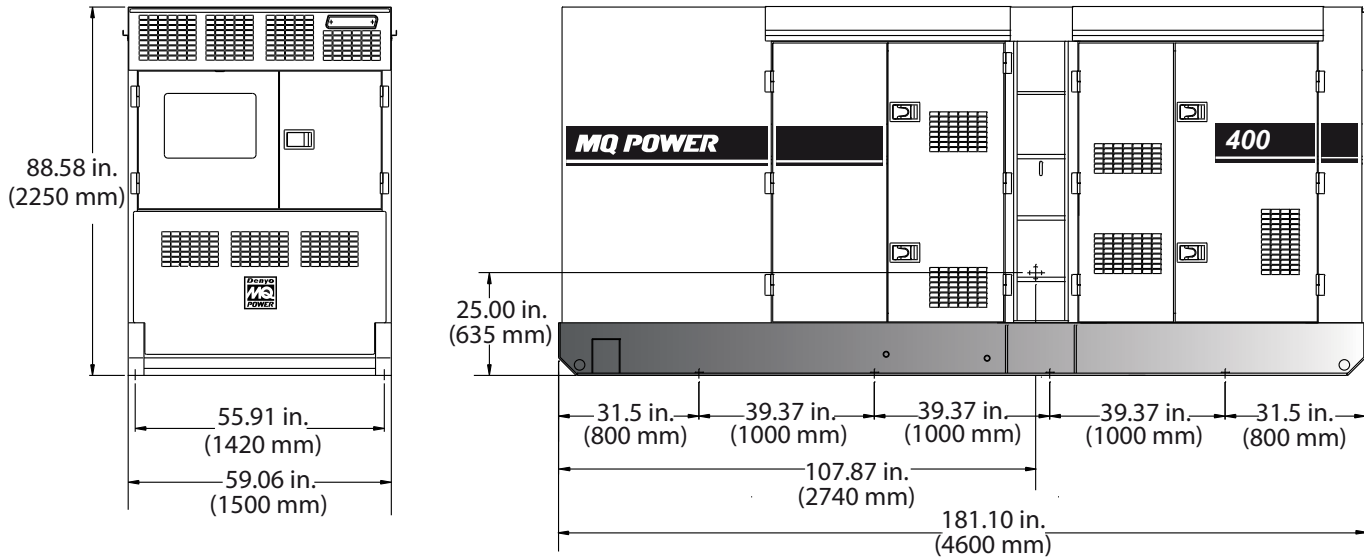

TRAILER-MOUNT DIMENSIONS

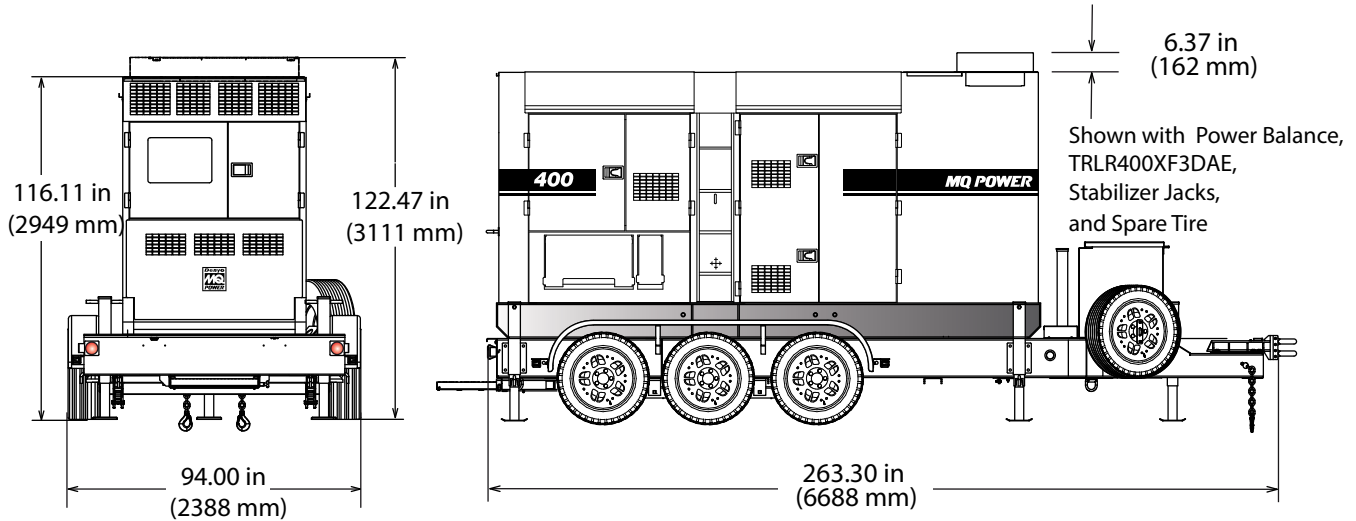

DCA400SSI4F3PB Weights**

| | |
|-----------------------------|------------------------|
| Dry Weight | 12,390 lbs. (5,620 kg) |
| Wet Weight* | 13,197 lbs. (5,986 kg) |
| Max. Lifting Point Capacity | 21,000 lbs (9,525 kg) |

DCA400SSI4F3PB and TRLR400XF3DAE Weights**

| | |
|--------------------------------|------------------------|
| Dry Weight (less fuel and DEF) | 16,745 lbs. (7,595 kg) |
| Wet Weight (with fuel and DEF) | 19,766 lbs. (8,966 kg) |

*Wet Weight includes engine oil, coolant, diesel fuel, and DEF.

**Weights do not include options.

Generator can be placed on MQ Trailer Model TRLR400XF3DAE.

NOTICE

Features and Specifications are subject to change without notice.



MULTIQUIP

6141 Katella Avenue Suite 200

Cypress, CA 90630

310-537-3700

E-MAIL: mq@multiquip.com

WEBSITE: www.multiquip.com

© COPYRIGHT 2024 MULTIQUIP INC.

DCA400SSI4F3PB Rev. #2 (07/22/24)